

# Compact Solar Power System

DX - 90 / DX - 60 / DX - 45

**SUNTECH**

Solar powering a green future™

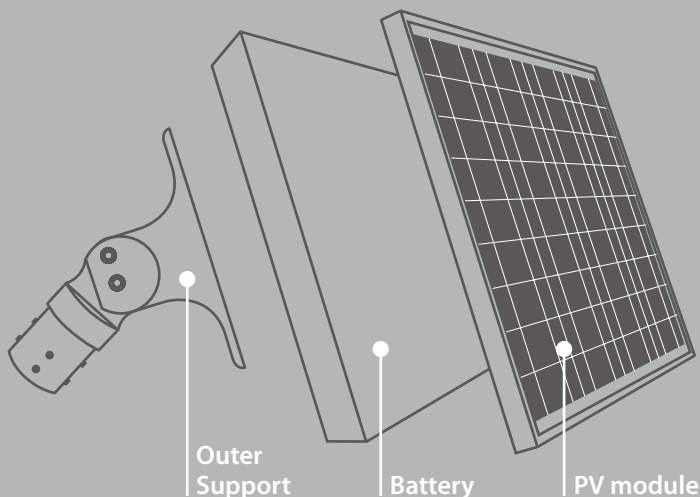

## Feature



Integrated system with highly efficient PV module, long-life battery and automatic control devices.



Features compact, high-capacity lithium iron phosphate batteries with minimum lifetime of five years.



Weatherproof, corrosion-resistant exterior maintains integrity even in extreme weather conditions.



Easy to install, maintain & repair, can be affixed on a variety of surfaces to prevent theft.



Wide range of uses—from street lights to illuminated banners and advertisements, among others.

## Product Warranty

- Total product warranty 5 years
- Batteries 5 years
- Solar module 20-25 years



## Technical Specifications

Series	DX-90	DX-60	DX-45
PV module	(STP-045-12Rb) x 2	(STP-060-12Sb) x 1	(STP-045-12Rb) x 1
Optimum Operating Voltage (Vmp)	17.6 V	17.4 V	17.6 V
Optimum Operating Current (Imp)	2.58 A	3.45 A	2.58 A
Open-Circuit Voltage (Voc)	22.0 V	21.6 V	22.0 V
Short-Circuit Current (Isc)	2.79 A	3.90 A	2.79 A
Maximum Pwer at STC (Pmax)	45 W	60 W	45 W
Operating temperature	-40 °C to +85 °C	-40 °C to +85 °C	-40 °C to +85 °C
Maximum System Voltage	715 V	715 V	715 V
Maximum Series Fuse Rating	10 A	15 A	10 A
Power Tolerance	+/-5%	+/-5%	+/-5%
Lithium iron phosphate battery capacity	12V70Ah	12V50Ah	12V40Ah
Charge controller / power supply	10 A	10 A	10 A
PV module tilt angles	5° 10° 25° 30° 45° 50°	5° 10° 25° 30° 45° 50°	5° 10° 25° 30° 45° 50°
Recommended load	25 W - 30 W	15 W - 20 W	10 W - 13 W
Recommended height of light	4.5 M - 5 M	3.5 M - 4 M	3.0 M
Vertical pole diameter	3.0 in (76.2 mm)	3.0 in (76.2 mm)	3.0 in (76.2 mm)
Total weight	35.3 kg	27.8 kg	20.6 kg
Size (mm)	1076 x 665 x 125	777 x 671 x 135	537 x 665 x 125
Product photo			

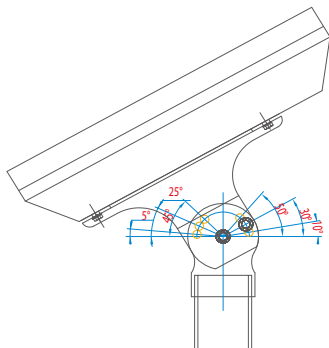

Distributor

### Suntech Power Holdings Co., Ltd

9 Xinhua Road, New District, Wuxi  
Jiangsu Province 214028,  
People's Republic of China

Tel: +86 510 8531 8888

Fax: +86 510 8534 3049

Customer Service Hotline:

+86 400 8888 009

Email: [sales@suntech-power.com](mailto:sales@suntech-power.com)